



MUD & DRILL CUTTINGS GRINDED FOR REUSE IN OIL FIELD

EQUIPMENT FOR GRINDING MUD

Environmental regulatory considerations play a significant role in the overall economics of drilling a well.

Operational costs regarding treatment and disposal of drilling waste can be significant reduced by grinding the material for optimized handling and injection.

Injection of mud onsite avoids the need to transport materials to an offsite disposal location.

Over the years Envitec and EUROmilling a/s have developed, manufactured and supplied robust grinding equipment to the oil industry in the North Sea.

Our product offering includes

- MUD Mill HTS-700
- ROLLER Mill HVS-300-300

Several mills are currently operating on platforms in Norway. Mud and drill cuttings are grinded into small particles for reinjection and making new mud.

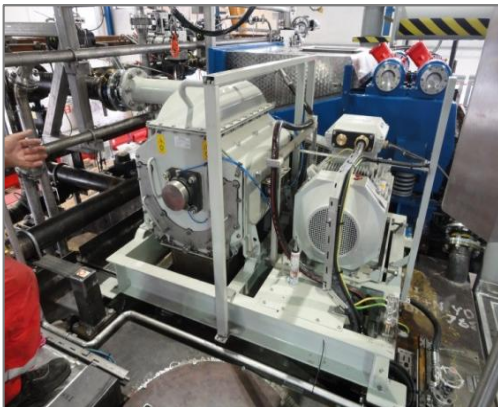



Our MUD Mill HTS-700 is made of steel and intended for the specific purpose of crushing drilling cuttings

Operating on several platforms in the North Sea

Injection of grinded MUD and drill cuttings saves large costs of processing and transporting MUD to shore for cleaning

MUD is pumped into the milling chamber. A rotor equipped with hard metal milling segments (Wolframcarbide) grind the material to a size smaller than 3mm

Why choose our MUD Mill HTS-700:

- Robust and safe technology
- Long lasting materials
- Central lubrication system ensures low maintenance
- Reduce number of production stop
- Quick change of screen
- Operators can start grinding process in no time
- No maintenance accessories
- Reduced service cost
- Low noise level ensures more working hours near the mill

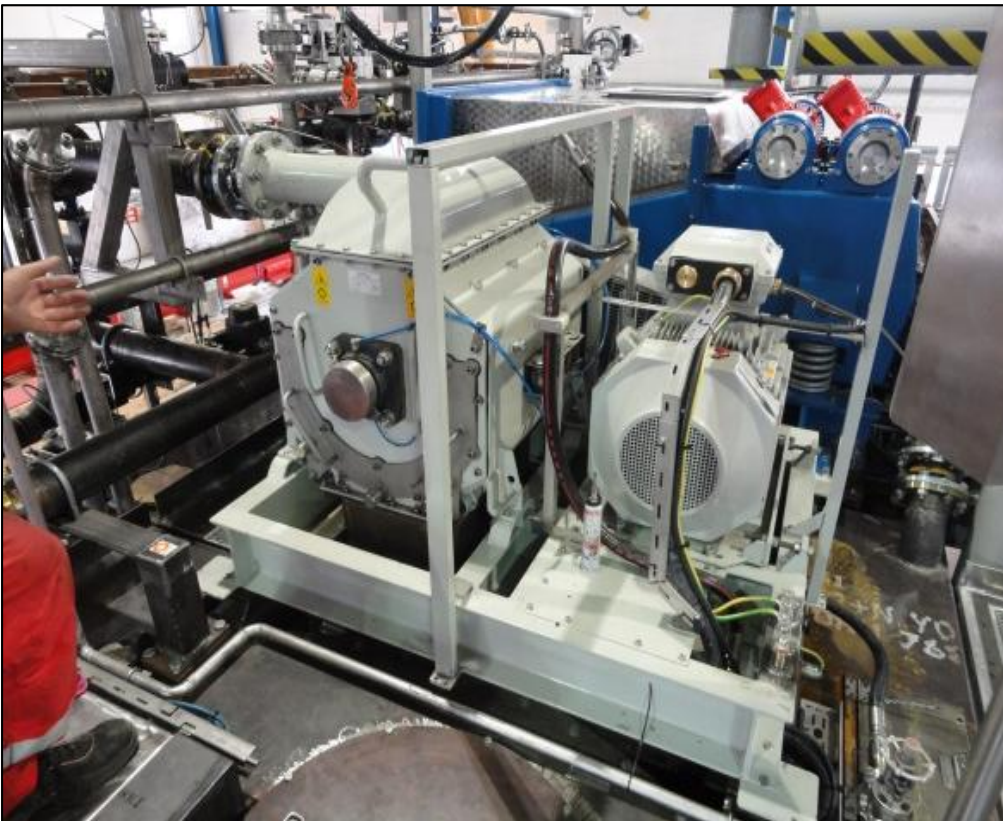

HALLIBURTON

AkerSolutions

Scomi

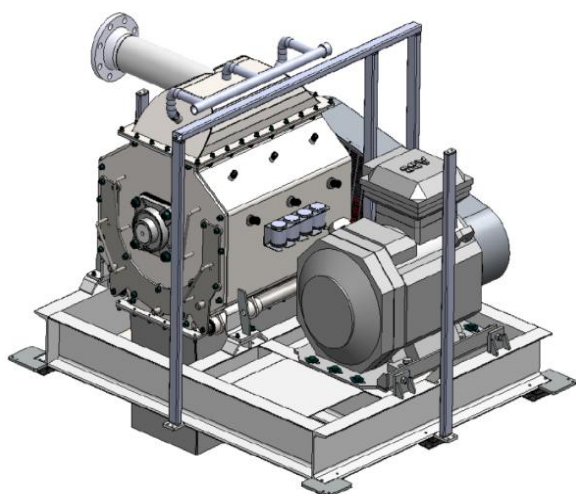

The MUD mill are driven by 8 V-belts, belt transmission and ATEX approved ABB IE2 Motor 55-75kW mounted on a adjustable console

There are 18 milling segments on the rotor and 12 milling segments in the milling house 6 in each side. The milling process is being carried out between the milling segments. The mill can run in both directions

The tray is supported by two large shafts, to make sure that the operator doesn't have to lift the tray

The standard screen is 3mm thick and with 3mm holes

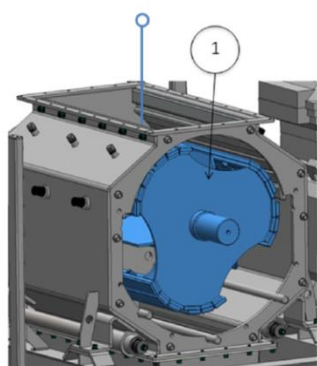
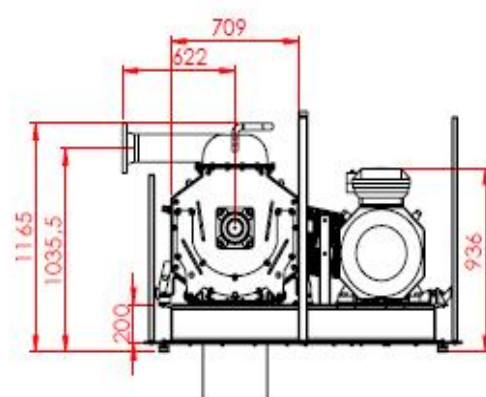
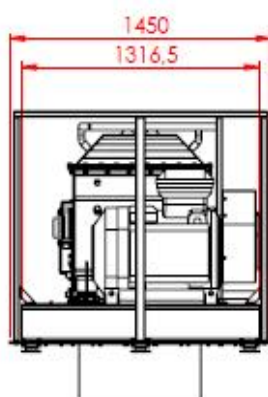
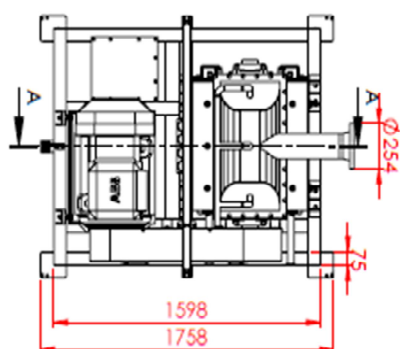
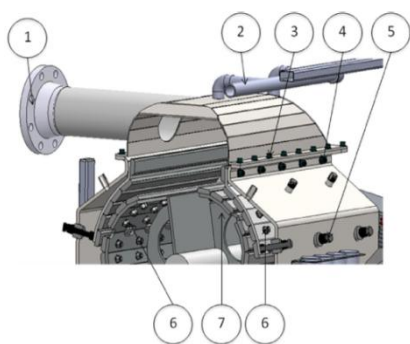

Motor	kW	55 – 75
Screen area	m ²	0,67
Hard metal milling segment on rotor	40 mm	18pcs.
Hard metal milling segment in milling house	40 mm	12pcs.
Capacity*	tons / h	Product dependent
Noise level	dB(A)	80
Noise level in sound box	dB(A)	70
Weight with motor	kg	1.800
* = The capacity depends on material / screen and motor sizes		

The Roller Mill HVS is made of stainless steel and intended for the specific purpose of crushing drilling cuttings

Operating on several platforms in the North Sea grinding hard materials found in the Norwegian underground

Roller Mill is equipped with 2 rollers coated with Wolframcarid; these are individually, but synchronously, driven "fixed rollers", which are adjusted to have a fixed desired distance, and are thus not in direct contact

EuroMilling A/S



Why choose our Roller Mill HVS-300-300:

- Long lasting materials; wolframcarid hardness of 10 (Mohs scale)
- Simple and safe technology
- Grinding hard materials
- Gives you the finest dust
- Lubrication system ensures low maintenance
- Reduce number of production stop
- Operators can start grinding process in no time
- Reduced service cost
- Low noise level ensures more working hours



HALLIBURTON

Schlumberger

Scomi



HALDOR TOPSØE



OFFSHORE ROLLER MILL

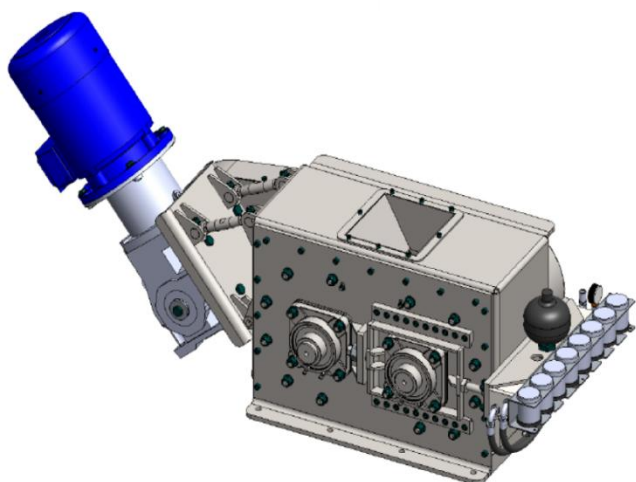

The rollers are driven by cog wheel belt transmission and a ATEX approved gear motor 5.5-7.5kW mounted on a adjustable console

The hydraulic tensioning system consists of two cylinders and one Diaphragm accumulator and a manometer. The pressure is applied / adjusted for one roller by means of a manually activated oil pressure pump. As the outset the pressure has been fixed at 75 bar

To ensure against overloading or foreign elements in the product, the rollers are fixed by means of a hydraulic tensioning system enabling the rollers to open

Materials grinded down to 120 micron

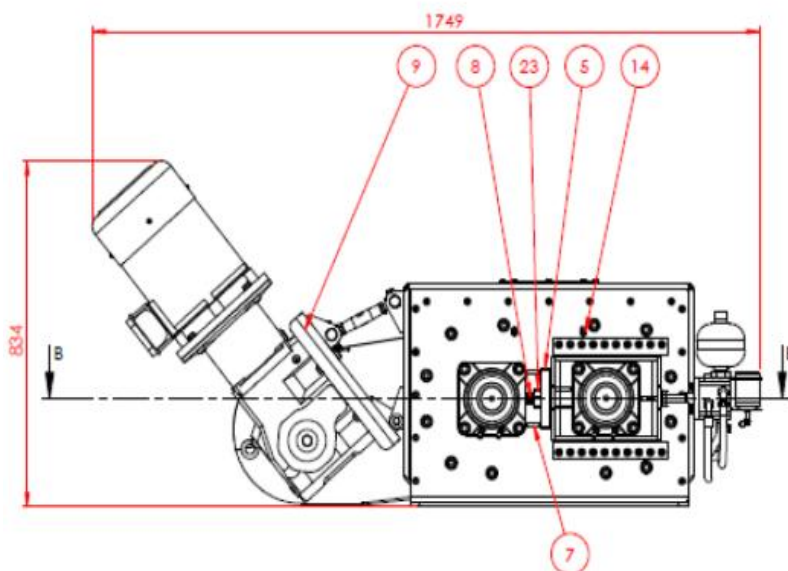
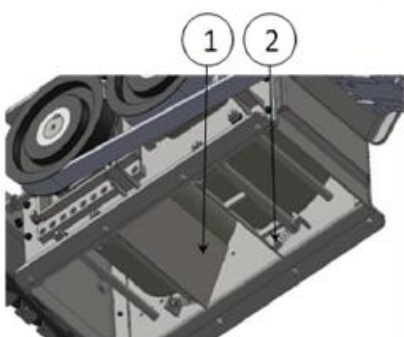
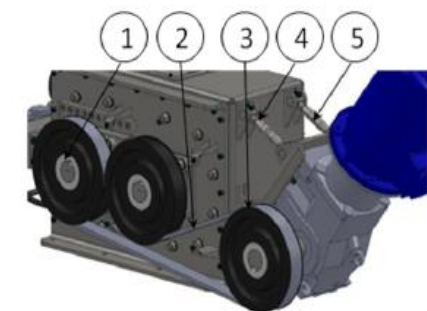

Motor	kW	5.5 – 7.5
Roller diameter	mm	Ø300
Roller width	Mm	300
Hard metal	Ni WC	2400HV
Capacity*	tons / h	Product dependent
Noise level	dB(A)	70
Weight with motor	kg	875

* = The capacity depends on material / screen and motor sizes

MUD MILL PICTURES

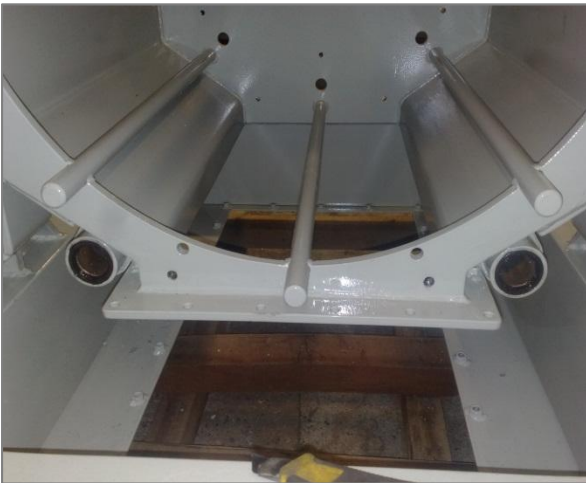
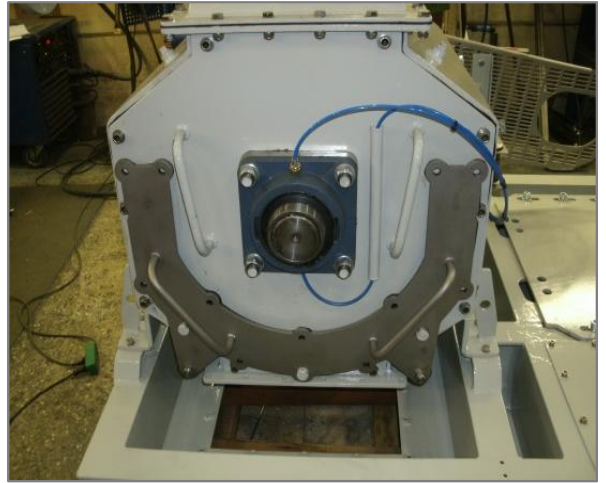

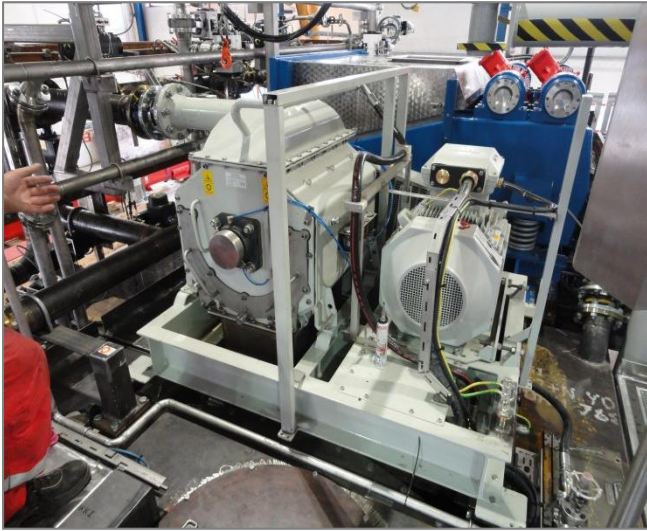



ENVITEC
Environmental Technology AS
Fabrikkveien 6
4323 Sandnes
Norway
+47 90 61 61 62
post@envitec.no
www.envitec.no